

Dynamic Simulation of Mechatronic Systems

R.Cresnik, A.Rieser, H. Schluder

Virtual Vehicle, Das virtuelle Fahrzeug Forschungsgesellschaft

Graz, Austria

Summary:

A growing number of safety systems are implemented in modern vehicles. Thereby vehicles become more complex and in succession the quantity of potential error causes is increasing. Numerical simulation and prototype tests are used to investigate vehicle behaviour and prevent aberrations at an early stage. However, prototype tests on full vehicle level are not feasible in early development stages. Numerical simulation is an effective tool reducing development time and costs, but hardware tests are still necessary to verify the simulation results. To handle these challenges in the development process new developing methods are necessary.

In this paper an interface, which provides the implementation of control systems into finite element solvers is presented. This interface allows a more realistic behavior of these systems in numerical simulation. Thereby it is a useful tool, to design and adjust mechatronic systems, like integrated safety systems, at an early stage of the development process.

This coupling method can also be used to check actuator configurations in substituted mechanical systems. Needed forces and accelerations are known before experimental testing, but disturbance variables cannot be pre-calculated. Therefore this method offers a possibility to verify, if the range of capacity of the actuator, the frequency and efficiency of the control algorithm are able to handle the prescribed behaviour.

In order to consider the behavior of all systems in a close to realistic manner, associated control units must be built into the finite element model. This will be a prerequisite for the realization of an optimized mechatronic system configuration in future vehicles.

Keywords:

Co-Simulation, Restraint System, Adaptive Safety System

1 Introduction

Increasing requirements in realm of vehicle safety continuously rise to challenges for the car developers. To become more flexible in creating of protection systems, mechatronic systems are more and more used. As these systems use actuators, it becomes possible to react to crash scenarios actively. The implementation of intelligent algorithms opens a completely new range of options. On the one hand the detection of crashes in the pre-crash phase by sensors allows an activation of protection systems before the impact. So several systems can be set to optimum behaviour in order to provide the best protection balanced to the expected type of impact. This can be used e.g. to lift the front lid immediately before a collision with a pedestrian occurs to activate pre-load devices. On the other hand, the safety systems can be regulated during the impact to an optimum of occupant loading. Active head restraint systems or adaptive safety devices like intelligent belt systems or airbags can be optimized concerning occupant loading for example.

However, it is very expensive to test these types of safety systems in hardware. Such tests have to be carried out in early phases of car development where only prototype parts are available. Because of the high costs of parts in these phases, substituted mechanical systems are used for analyses and tunings of restraint systems and other safety devices. In order to get useful test results control mechanisms are very important too. To imitate the behaviour of crash scenarios by sled tests it is crucial to reproduce acceleration pulses of the real vehicle crashes. Furthermore, several types of intrusions have to be realized. For getting reliable test results, it is fundamental to measure the basic conditions like acceleration pulse in a reproducible way. More complex pulses are only realizable by using control algorithms for the actuators.

In FE crash simulations it has not been possible to include complex control systems and sensors until now. However, steering algorithms were not controlled but simulated. To analyse more complex systems that contain closed control loops, it is necessary to implement the control algorithms into the simulation. To connect the control software with a Finite Element Solver, it is possible to advance the behaviour of the control algorithm and get a realistic representation of the system which includes actuators. To provide this possibility of co-simulation a coupling system has been developed. Therefore user defined subroutines have been implemented into the commercial version of LS DYNA. This active interface between LS DYNA and Matlab/Simulink®, Microsoft Office Excel 2007, etc. allows active reactions in Finite Element models to sensed events and cinematic values by using intelligent algorithms.

The benefits of our coupling method are manifold: by applying this method, it is possible to check control algorithm without the need of hardware systems in early phases of development. In later phases that kind of simulation can be used to reduce the number of hardware tests. The simulation can be validated by tests, and parameter studies can be done in numerical simulation without great effort like hardware tests cause. This kind of design process can be used e.g. for the development of active, adaptive restraint systems. The control algorithm could aim a defined maximum of occupant displacement, forces of restraint systems can be regulated to a minimum that way. This will be discussed later.

This coupling method can also be used to check actuator configurations in substituted mechanical systems. Needed forces and accelerations are known before experimental testing, but disturbance variables cannot be pre-calculated. Additionally this method offers a possibility to verify, if the range of capacity of the actuator, the frequency and efficiency of the control algorithm are able to handle the prescribed behaviour.

2 Operation mode of the coupling system

The described coupling-software allows communication between LS DYNA [1] and other software like Matlab/Simulink®, Microsoft Office Excel 2007, etc. at every time step. So it is possible to have access to the full range of cinematic data of the Finite Element Models-system which will be processed in the control algorithms. To speed up the system, the communication software provides a possibility to skip a defined number of steps in every loop by freezing the exchanged values. Generally, it is not necessary to use the whole range of data because of the small time steps in simulation. Common time steps around 1e-6 seconds are used, so, in case of usage of the full range, it is possible to simulate with a control frequency up to 1MHz.

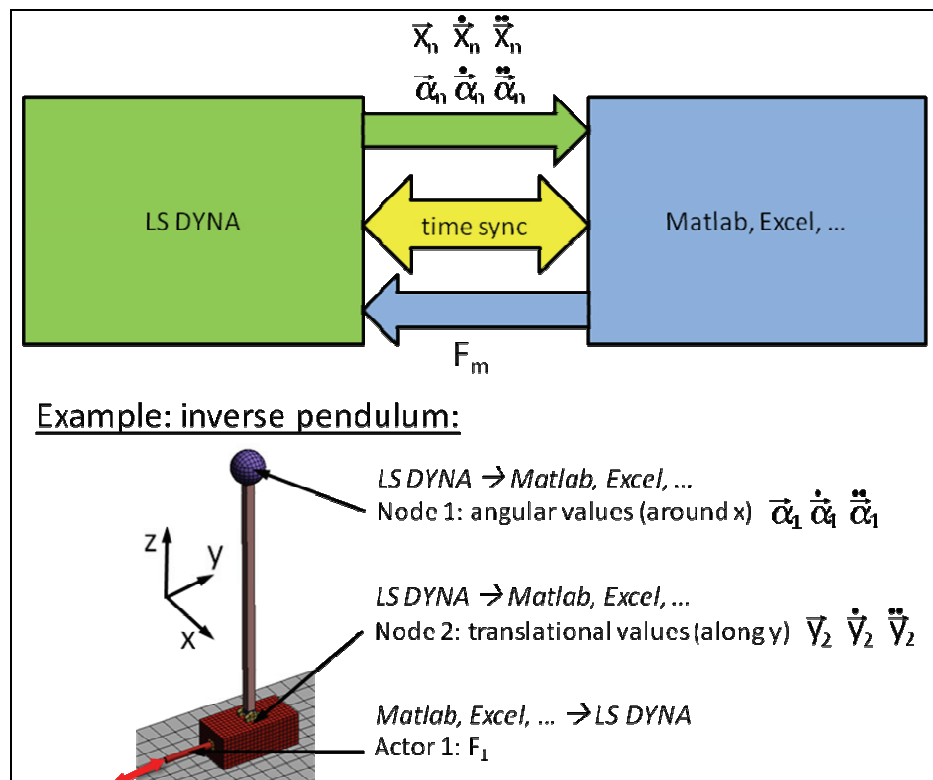

Figure 1: Mode of operation

In the current version the coupling software is able to send translational and rotational values of predefined nodes from LS DYNA to other software. The control software sends back force values to LS DYNA that will be placed as forces at predefined bar elements into axial direction (see Figure 1). A synchronizing algorithm ensures that both applications are working with the same simulation time at point of communication.

The prototype of the control software was built up in Visual Basic in Microsoft Office Excel 2007. This programming language provides a very fast way to implement and optimize the communication algorithm. In a further step a communication module was implemented into Matlab/Simulink®, which provides a more professional way of building up control loops.

To pretest the functionality of the coupling software, several small examples have been built. These calculations were very useful for improving the process of building up and simulating a coupled system (see Figure 2): they are simple enough to get results in an adequate time, but complex enough to show the whole coupling process. One of the most common examples to demonstrate control is the "Inverse pendulum" (see Figure 1). The aim of this exercise is to stabilize a pendulum, which is loaded by disturbance variables in opposite direction to the gravity. The coupling was able to handle this challenge.

To build up a coupled Finite Element Model of an inverse pendulum, additional work, which is described below, has to be done.

The LS DYNA- output nodes have to be listed in a separate definition file, including node number, type of output (way, translational velocity, translational acceleration, angle, angular velocity or angular acceleration) and direction (global x, y or z). The actuators have to be defined in the input LS DYNA input and are represented by specific bars.

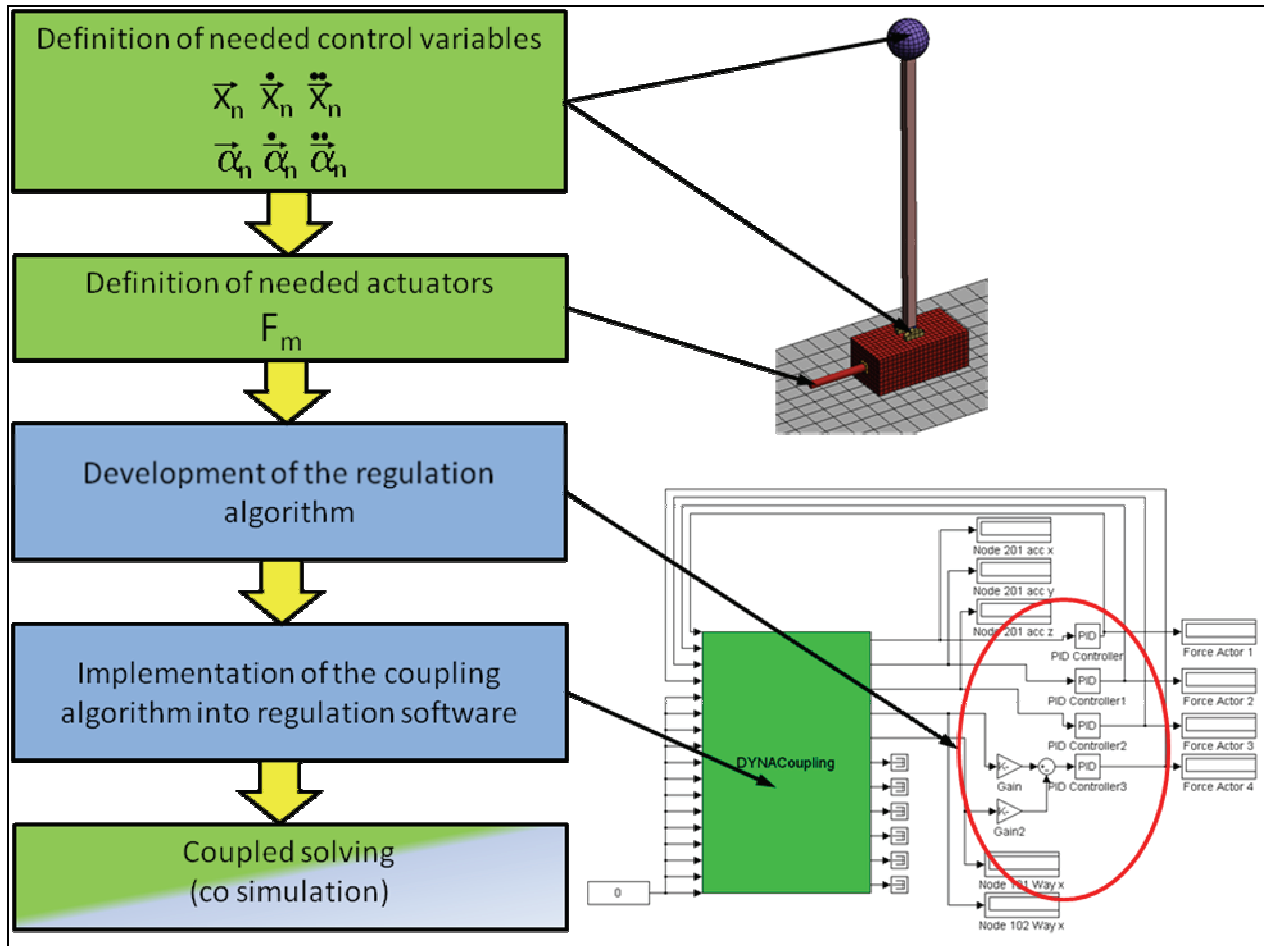

Figure 2: Process of implementation

It is possible to prepare the input deck in standard pre-processors like usual. There are only a few marginal changes that have to be done by using a simple macro or a text editor.

For further work, it is projected to expand the coupling software by implementing force sensors.

3 Implementation into ICOS [2]

To connect LS DYNA with several different control software packages, it would be necessary to implement lots of different coupling routines. As an alternative, the Competence Centre Virtual Vehicle provides a co-simulation tool, called ICOS (see Figure 3). This software has been developed for the coupling of numerical simulations in the range of thermal management. In that special field, many different non-standard simulation tools are used for different subsystems, the combination of systems can vary from project to project. However, to get overall results, it is necessary to couple these systems. Therefore a multifunctional independent platform is necessary.

To handle this challenge, specific interfaces for the different types of software have been developed. The single software packages are represented by black boxes with defined input and output variables which can be coupled to each other. The simulation platform operates independently from the coupled software. The core function of ICOS is to enable the data exchange between simulation tools of different architectures and operating systems. It provides algorithms to ensure numerical stable and physical correct interaction between the subsystems.

Furthermore, ICOS can be used for a wide range of simulations including driving dynamics software with multi body models, sensor emulating software and control software to simulate pre-crash and crash phase continuously. As a consequence boundary conditions, initial positions and forces in Finite Element crash simulation will show a better fit to real world crashes [3].

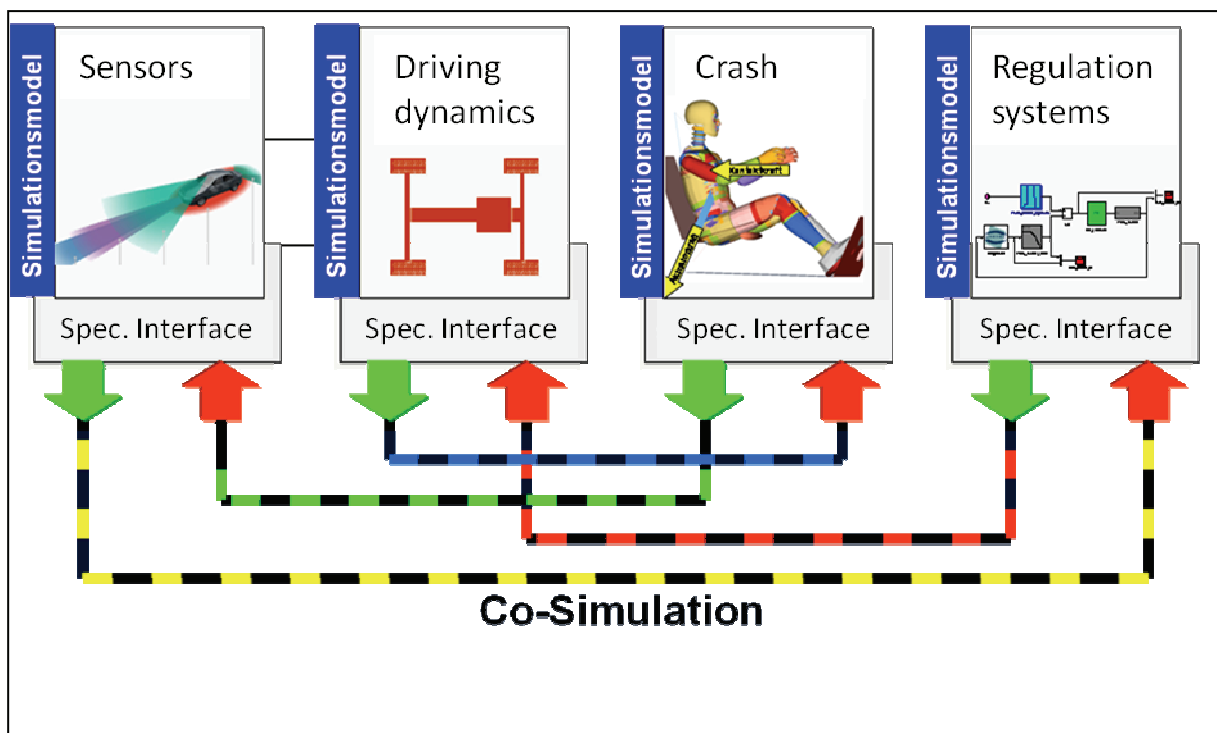

Figure 3: Example ICOS

4 Example for application

General facts

Future vehicles will be equipped with adaptive passive safety systems, including such things as adjustable belt load limiters, airbags and steering columns. Components of active safety systems provide the potential for intelligent passive safety systems. The combination of these two systems is called "Integrated safety". Sensors of active safety systems deliver essential information to a safety controller, which identifies an imminent accident in order to adjust the passive safety components. Using special algorithms, the safety controller computes the estimated crash load case, collision speed, mass and stiffness of the opponent, in order to predict the acceleration behavior of the passenger compartment. Additionally, weight, height and seating position of the occupant will be taken into account. With this information, it is possible to set up trigger times and force levels for the restraint systems that provide a minimized occupant loading [4].

Front Crash Model

To demonstrate the functionality of the LS DYNA-Matlab/Simulink® interface and the potential of the adaptive restraint system, a substituted finite element model of a front crash, vehicle versus rigid wall was built (see Figure 4).

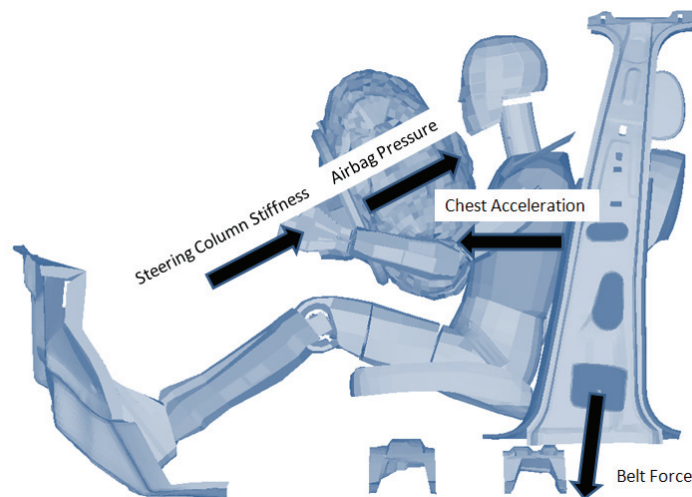

Figure 4: Finite element model with Lstc's Hybrid 3 dummy and restraint systems

In this model, Lstc's Hybrid 3 dummy is seated in a rigid seat contour. To keep the simulation simple, a non-adaptive assembly of the airbag and steering column model is used, and only the chest acceleration is considered as an injury criterion. Other adaptive systems are still under investigation. The finite element model of the belt is connected with a safety unit built in Matlab/Simulink®. To generate the acceleration behavior of a passenger compartment, a simulation of a Ford Taurus [5] with three different collision speeds (28, 42, 56kph), which cause airbag activation, was conducted. Collision speeds over 56kph were not considered, because the main injury mechanisms change. Whereas acceleration-caused injuries predominate at collision speeds under 56kph, additional intrusion-caused injuries occur at collision speeds over 56kph. One reason for this is that legal and consumer tests against rigid walls are conducted at collision speeds of nearly 56kph, so restraint systems are optimized for this speed, in order to achieve the best test results. Another reason is that the passenger compartment starts to collapse at collision speeds over 56kph.

Safety Unit

The safety unit, depicted in figure 5, contains a safety controller which delivers trigger time and initial force levels for the belt system based on the oncoming acceleration and speed of the passenger compartment. During the vehicle crash, the safety unit monitors the acceleration and velocity of the

vehicle and the displacement, velocity and acceleration of the chest. This data is processed by an installed belt controller, which adjusts the belt load limiter in order to affect the chest acceleration. In order to protect the occupant, the belt traction force is limited to a maximum of 5000N. The goals are to capitalize on the free space between the dummy and the steering wheel, and to reduce the maximum and average chest acceleration in every load case as the vehicle crash occurs.

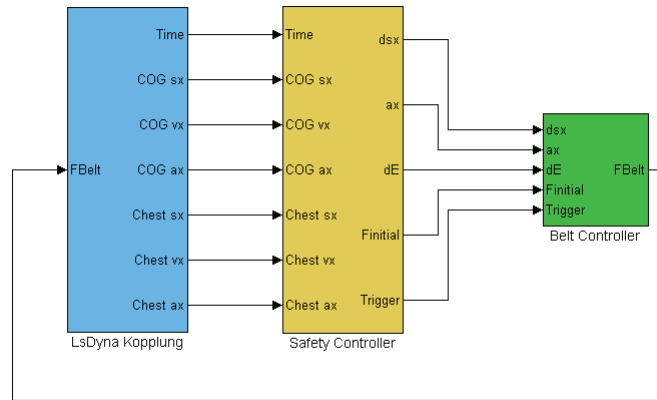

Figure 5: Safety Unit built in Matlab/Simulink®

Results

The following three figures (Figure 6 to 8) present the simulation results. In each pair of charts, the figure above shows the chest acceleration. The reference system is represented by the solid red line, and the adaptive system by the dashed blue line. The lower figure in each pair displays the relevant operating force of the adaptive load limiter.

As depicted in figures 6 and 7, the main improvements of an adaptive system are at collision speeds under 56kph, because the reference restraint system reacts too aggressively. The main advantage of the adaptive system is its ability to react to important influencing variables. It provides a timely reaction to the vehicle acceleration and airbag activation. In addition, compared to the reference system, the adaptive system can set an earlier trigger signal, which allows the system to take full advantage of the entire free space between steering wheel and occupant. This results in a constant, low level of chest acceleration during the whole crash and yields significantly lower maximum and average acceleration rates than the reference system.

As figure 8 shows, the potential to minimize the occupant loading at collision speeds of nearly 56kph is less than at lower speeds, because the restraint systems are optimized for this configuration, as mentioned above.

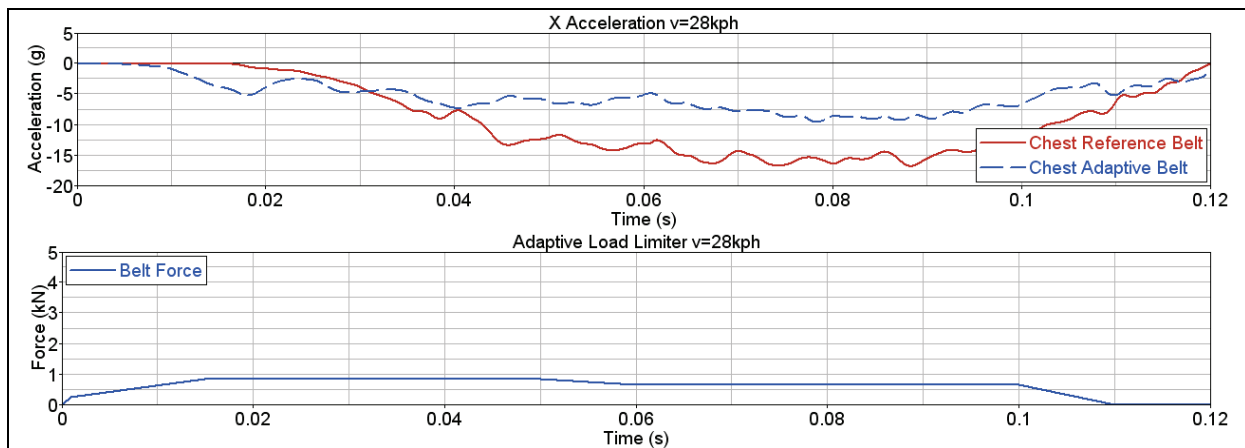

Figure 6: Chest acceleration and Belt force at 28kph collision speed

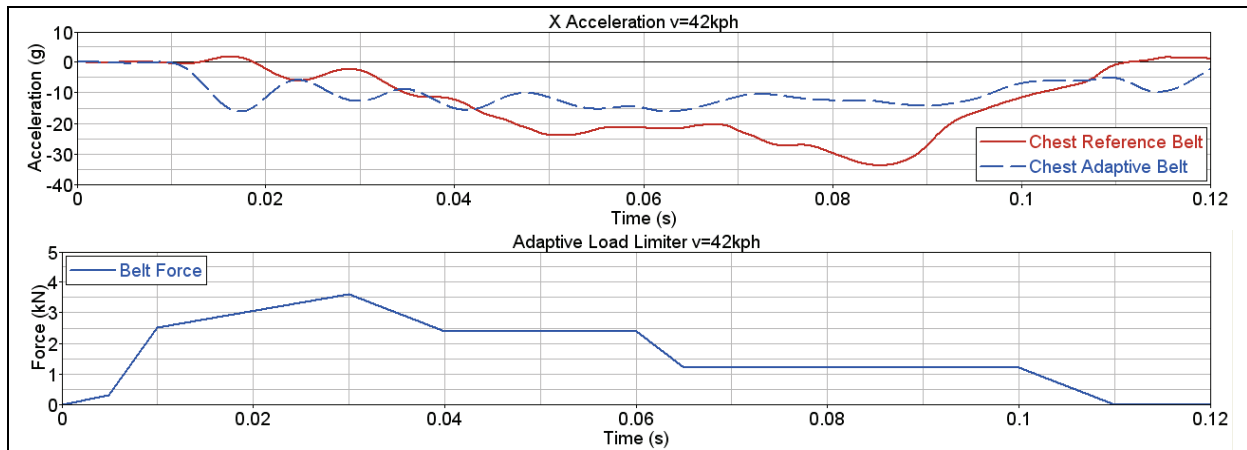

Figure 7: Chest acceleration and Belt force at 42kph collision speed

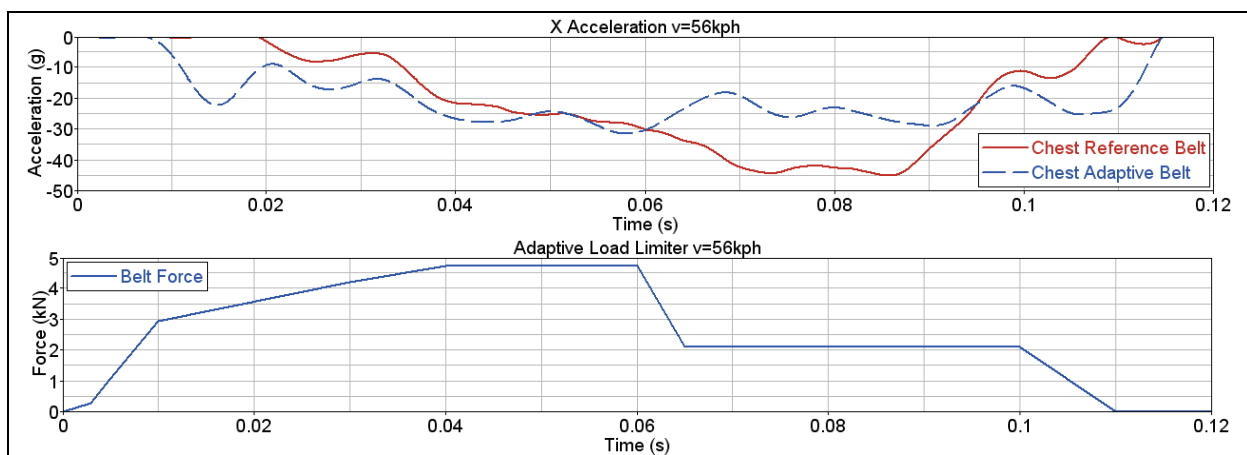

Figure 8: Chest acceleration and Belt force at 56kph collision speed

5 Conclusion

In order to improve on current restraint systems and to achieve higher safety standards, Co-simulation will become an increasingly attractive development method in the division of car safety. Each future restraint system, which will be characterized by variability, will contain a control system, and all systems will interact. Airbag, steering column and belt will be connected to a safety unit which can be adjusted to optimize occupant loading for every crash condition. To accomplish this, the safety unit will monitor every relevant injury criterion of the occupant. Based on this information, the safety unit will control the action of every system and provide an optimized interaction.

In principle, the Co-Simulation tool will allow for the simulation of any assembly, which itself represents a complex, mechatronic system.

In order to consider the behavior of all systems in a close to realistic manner, associated control units must be built into the finite element model. This will be a prerequisite for the realization of an optimized restraint system configuration in future vehicles. The interface between LS DYNA and Matlab/Simulink® has been developed for this purpose.

6 Acknowledgement

The authors wish to thank the “COMET K2 Forschungsförderungs-Programm” of the Austrian Federal Ministry for Transport, Innovation and Technology (BMVIT), the Austrian Federal Ministry of Economics and Labour (BMLWB), Österreichische Forschungsförderungsgesellschaft mbH (FFG), Das Land Steiermark, and Steirische Wirtschaftsförderung (SFG) for their financial support.

7 Literature

- [1] Livermore Software Technology Corporation (LSTC), "LS-DYNA Theory Manual", 2006
- [2] Puntigam W., Hörmann T., Moshhammer T., Hager J., Jimenez C. 2005, "Thermal Management Simulation by Coupling of Different Software Packages to a Comprehensive System", VTMS SAE Technical Paper 2005-01-2061, Toronto, Canada
- [3] Schluder H., Cresnik R., Wallner D., Eichberger A. 2008, „Kopplung von aktiven und passiven Sicherheitssystemen über eine unabhängige Co-Simulationsumgebung“, Proceedings of Integrated Safety 2008
- [4] Wallner D. Eichberger A., Hirschberg W. 2009, "A Novel Control Algorithm for Integration of Active and Passive Vehicle Safety Systems in Frontal Collision", 2nd International Multi-Conference on Engineering and Technological Innovation
- [5] National Crash Analysis Center (NCAC), "Finite Element Model of the FORD Taurus", Model Year 2001, Version 3, retrieved 22/05/2008, from <http://www.ncac.gwu.edu/vml/models.html>